

## Introduction

Thank you for purchasing Shifter Vortex engines. This manual contains information to help you to get the best results from your new engine. Furthermore, it will explain you how to operate your Vortex engine safely and in a proper manner. All the information in this manual is based on the latest experience and product information available at the time of writing. Vortex reserves the right to make any kind of changes to this manual at any time without notice and/or incurring in any obligation.

OTK KART GROUP s.r.l.  
Via dei Soprini 16  
25080 Prevalle (Brescia) IT

VORTEX Factory  
Via E. Fermi 5  
27040 Campospinoso (Pavia) IT

[support@vortex-engines.com](mailto:support@vortex-engines.com)

## TABLE OF CONTENT

Chapter	Information	Page
<b>1</b>	<b>GENERAL INFORMATION</b>	
	Symbols	3
	Safety information	3
	Technical specifications	4
	Special technical specifications for homologated engine	5
	Packaging	5
<b>2</b>	<b>ENGINE ASSEMBLY</b>	6
	Engine bracket	7
	Coil	8
	Spark plug	10
	Fuel pump	11
	Carburetor	12
<b>3</b>	<b>ENGINE RUNNING IN</b>	16
<b>4</b>	<b>MAINTENANCE</b>	17
	Maintenance schedule guide and adjustments	17
	Torque chart	17
	General tolerances	17
	Maintenance detail chart	18
	Carburetor cleaning	18
	Chancing main jet	19
	Spark plug cleaning and replacement	20
	Cylinder head cleaning	21
	Cylinder check and maintenance	22
	Piston check and maintenance	23
	Cleaning and/or replacing clutch	24

## GENERAL INFORMATION

### SYMBOLS

Pay attention to the symbols of this manual. They alert you of dangerous situations for you or for your engine.



Personal Injury



Mechanical Danger



Caution



In order to perform a job, special tools are requested.



### SAFETY INFORMATION

- Do not start the engine indoors garages, trailers etc. Start the engine in a well---ventilated area only. Exhaust emission are hazardous to your health.
- Always wear gloves and proper clothing when working on your engine.
- Use caution when handling fuel, as fuel is very flammable and explosive. When working with fuel, do not smoke or use it near fire or flames. Avoid any skin contact and inhaling fuel vapors.
- Never touch moving parts when the engine is running.
- During operation, both engine and muffler, become very hot. Do not touch them and do not place anything on them after operation.
- Do not touch the spark plug or cable. It may provoke electrical shocks.
- Understand the operation of all controls and learn how to stop the engine quickly in case of emergency.
- Do not use the engine without clutch cover and chain protection.

---

# Shifter Engine Manual

---

## TECHNICAL SPECIFICATIONS

Engine		Max	Min
Displacement	124.36 cc	126cc	
Bore	54.00 mm	+0.2 mm	
Stroke	53.90 mm	54.08 mm	-0.10 mm
Squish			1.15mm/min
Combustion chamber			13 cc

Intake System		
Inlet	Reed valve at crank case	
Carburetor	Dell'orto	WHSH 30
Air box type	As per homologation file	
Main jet	As per homologation file	
Mixture needle	As per homologation file	
Jet min.	As per homologation file	
Idle diffuser	As per homologation file	

Ignition System	Type	Space
PVL	Analogic	
Recommended time setting		3 mm
Sparkplug	NGK B10 EG (recommended)	

General	Type	
Mix	4%	
Gear Oil	280 g W10/40	JASO MA-2 o API SL
Engine Weight	19 kg	

- All sizes and measurements in this manual are expressed in metrics.
- Always use original Vortex parts and proper tools when working on your engine.
- Proper fuel mix is necessary for optimum engine life and performance.

---

# Shifter Engine Manual

---

## SPECIAL TECHNICAL SPECIFICATIONS FOR HOMOLOGATED ENGINES



Every engine is specified according to the homologation of its country. For specific rules and/or sizes refer to your country homologation file

## PACKAGING

Your engine will be packed in a sealed box with the Vortex logo printed on and a sticker with model and serial number attached. In a complementary box all the accessories as carburetor, muffler and more will be provided.

The boxes need to have the original vortex logo.



The engine box an official OTK KART USA sticker.



And on the engine starter motor there needs to be an official OTK KART USA sticker too.



---

# Shifter Engine Manual

---

## ENGINE ASSAMBLY



In order to assemble the engine, you will need the following tools:

Type	Size
Compressed air	
Allen T-wrench	3 mm
Allen T-wrench	4 mm
Allen T-wrench	5 mm
Allen T-wrench	6 mm
Allen T-wrench	8 mm
Fixed wrench	5 mm
Fixed wrench	7 mm
Fixed wrench	8 mm
Fixed wrench	10 mm
Fixed wrench	14 mm
Fixed wrench	17 mm
Fixed wrench	22 mm
Crosshead screwdriver	
Spark plug wrench	
Plier	
Torque wrench	
Heater	
Metal brush	



### Compressed air

Unpack the engine and remove any packaging material on it. Clean the engine with compressed air and after take of the protecting PVC cups on the inlet, exhaust and spark plug.



### ENGINE BRACKET



#### 6mm T-wrench

Lay the engine on its side and attach the engine mount to the engine base with four 8mm Allen screws. Engine mount and screws come with the engine.

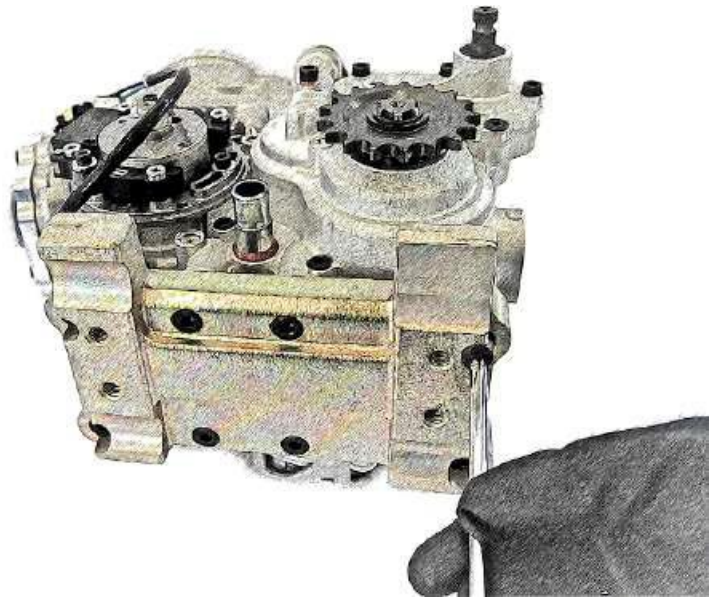

#### 10mm Allen T-Wrench

Warning: Engine comes with **NO** oil.  
Do not start the engine before filling it with oil. Remove the oil filler cap with 10mm Allen T-wrench and fill with **280gr** of engine oil, viscosity W10/40 (type JASO MA-2 or API SL).

Replace the oil cap.

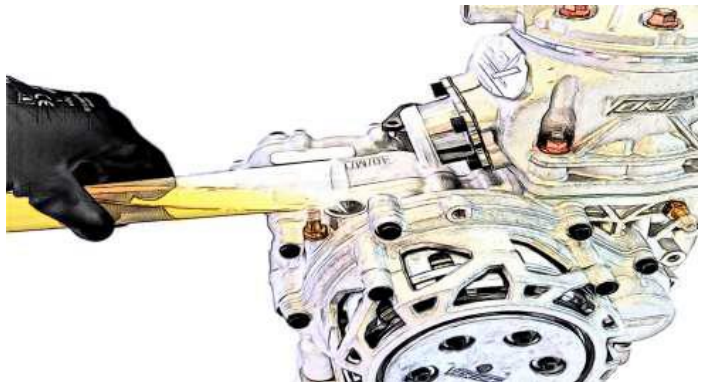



## Coil



**10mm fixed wrench**  
**4mm T-fixed wrench**

Assemble coil support and coil as per instructions. All needed parts come with the engine.

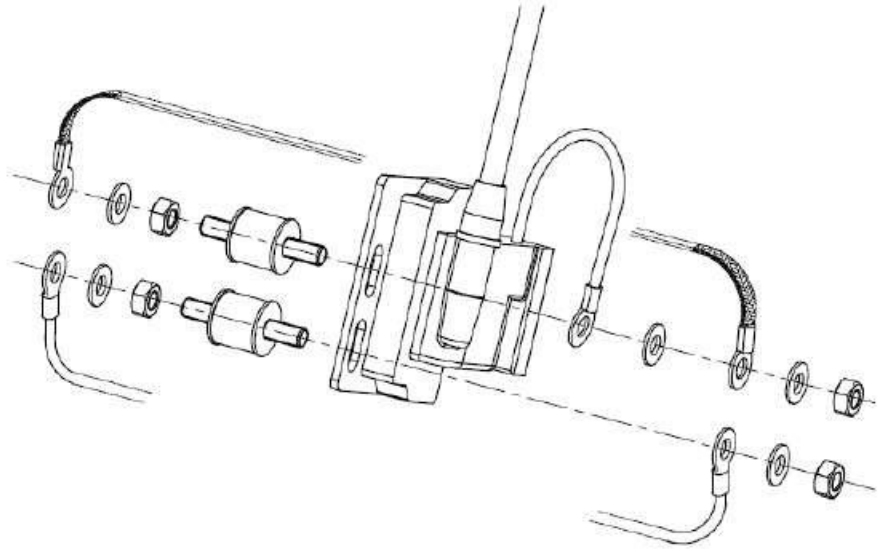

Assemble the two silent blocks on the coils support plate in the engine by inserting between the plate and the silent block the ground cable.



Insert coil in the two silent blocks.

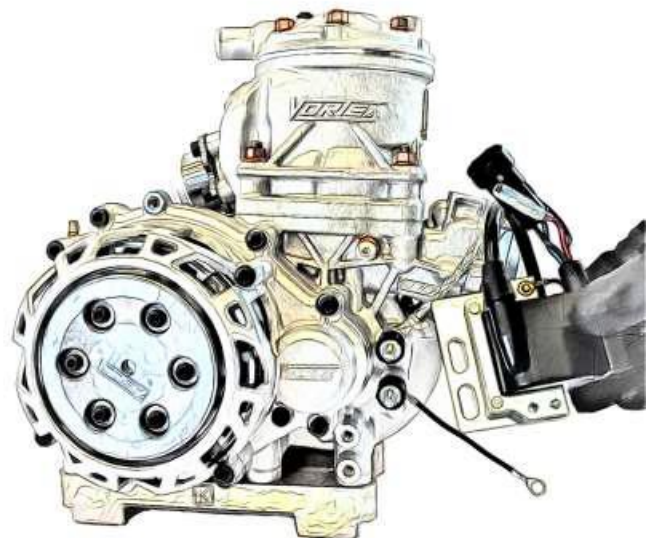



Insert ground cable from the coil and the other end of the ground cable in the silent block.



Fix ground cables and the coil to the silent block by using M6 nut and washers provided.



Be careful when assembling ground cable, the end must be in contact with the coil metal support, the other one in contact with engine crank case. Wrong assembling will result in coil failure and/or the engine will not start. Connect the coil connector with the starter connector.

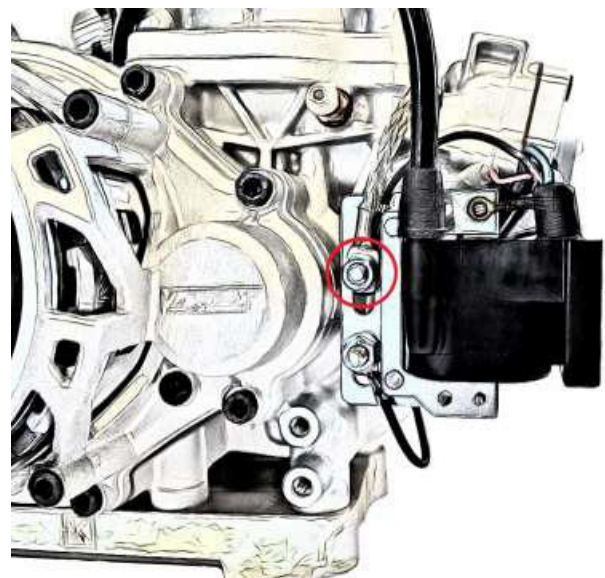

### SPARK PLUG

Unbox the spark plug, the ignition distance must be 0.8 mm like in the drawing below

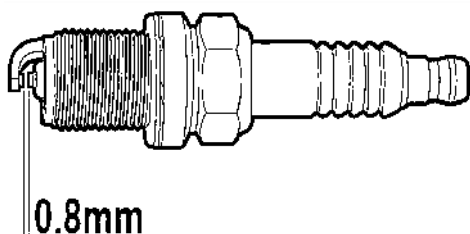

### Spark plug wrench Plier

Remove the PVC cap with the plier from the cylinder head.

Manually tighten the spark plug into the cylinder head.

Lock and unlock with the spark plug wrench 2/3 times to allow the gasket to seat properly. Now you can tighten the spark plug properly.



Insert the cable coil in the spark plug cap and tighten it.

For safety, we recommend you to secure the cable coil to the spark plug cap with a plastic strap. Place the spark plug cap on the spark plug and press the cap fully.



## FUEL POMP



10mm fixed wrench  
5mm fixed wrench

Place the fuel pump in the specific fuel pump bracket as per scheme.

All material needed comes with the engine

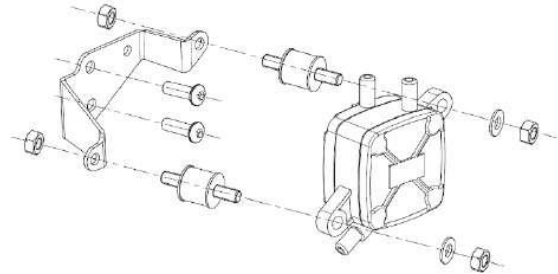

When the fuel pump is placed on the engine insert the pulse line at pictured (red arrow).

Later on, the other two lines will be assembled.

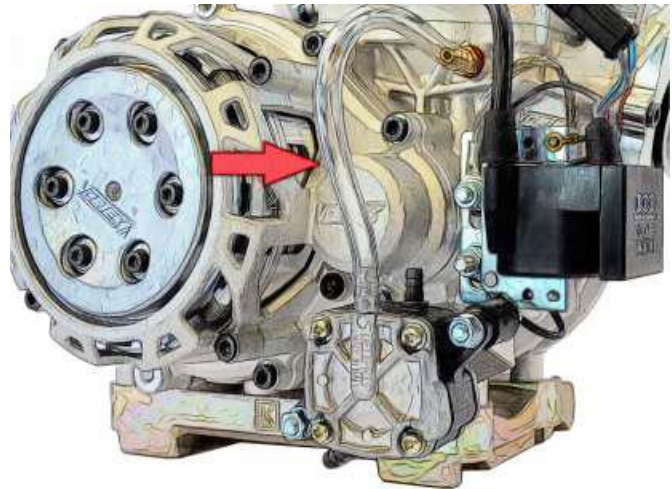

## CARBURETOR



**Screwdriver**  
**Flat plier**  
**8 mm fixed wrench**

Remove the plastic cap from the intake manifold.

Remove the carburetor from the box.

Put the metal retaining clamp provided with the carburetor, on the rubber intake manifold boot.

Push the carburetor firmly into intake manifold boot.



Making sure that the carburetor is in the manifold in the correct position, secure it with the metal retaining clamp provided.

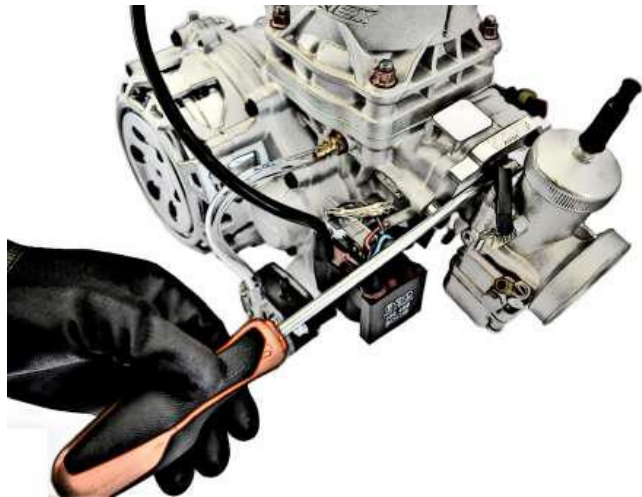



---

## Shifter Engine Manual

---

Remove the upper part of the carburetor by unscrewing the cap. Secure the throttle cable screw on top of the carburetor cover.

Feed the throttle cable inside the register and the carburetor cover making sure to leave the cable inside.

Feed the throttle cable through carburetor slide spring. Pull the slide from the carburetor.

Place the ball at the end of the throttle cable through the hole in the center of the slide. Lock the throttle cable inside the slide by moving the cable to the side to the center.

Place the slide and the spring in the carburetor. Replace the cap of the carburetor to the carburetor itself, screwing manually.

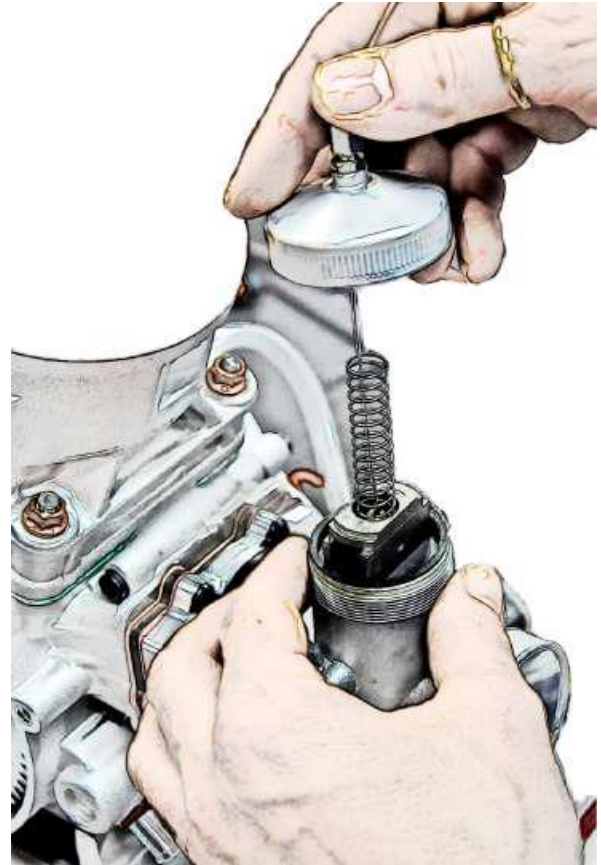

Very carefully, by using the pliers, turn the two carburetor vents so that they are facing up.



Place the vent line supplied on each of the two vents. Cut half of the line in the center, to create a vent hole.

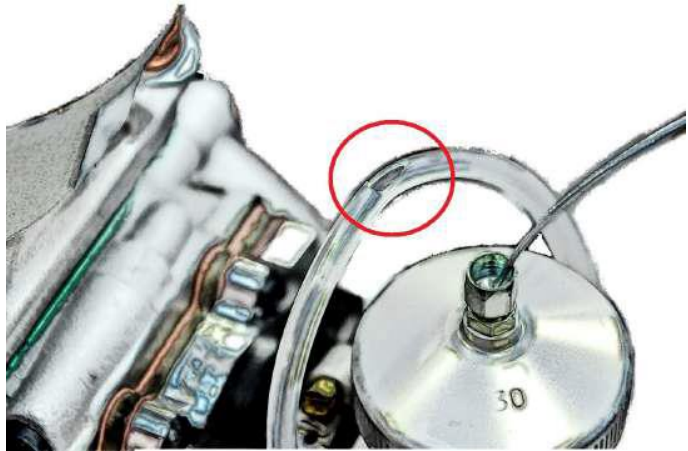

Insert fuel line from fuel pump to carburetor. Secure fuel line with a plastic zip tie.

**RACCORDO DEPRESSIONE**  
**DEPRESSION PIPE FITTING**

**SERBATOIO / TANK**

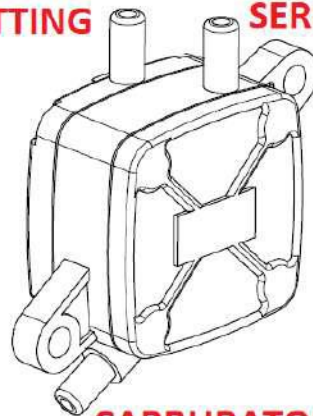

**CARBURATORE / CARBURETTOR**





### 10 mm Fixed Wrench

Place the clutch cable register. Later on, when engine will be placed in the chassis, will serve to get a proper tensioned clutch cable.



### 5 mm Fixed Wrench

Assemble gear lever before placing the engine in the chassis. Install the lever on the shaft and tighten it with the Allen screw.



Place and tighten the Allen screw  
AFTER placing the lever in the shaft.



### ENGINE RUNNING IN

#### ENGINE BREAK IN

Only a proper break-in will insure the best performance out of your engine in the future and guarantee its long and trouble-free life. Break-in is required when an engine is new or has undergone a major service of the engine's main parts (piston, cylinder, connecting rod, etc.).

Prepare fuel. Vortex engine works with commercial gasoline, leaded or unleaded, as well as racing fuel, with minimum 95 Octane. Mix Oil and fuel at 4% (i.e. 40cc of oil every 1.000cc of fuel). Use high-quality synthetic oil specifically made for kart engines. Vortex suggests Petronas Rok Lube, however other brands with the same composition might be suitable.

Shake the can thoroughly to mix the fuel and the oil properly. Then fill the gas tank in your kart.



A mistake in measurements could result in engine damage.



**Do not accelerate** fully but only partially.

Check that the cooling system warms up evenly; in case it warms unevenly proceed again with the bleeding of the cooling system.

Once the engine is warmed up and the cooling system works properly, proceed to the track. Run the engine by alternating RPM's a few seconds on and off the throttle at 3/4 maximum throttle.

Do not hold the throttle at a constant speed. Continue this way for 5/6 laps and return to pits. Check everything on the kart is tightening properly.



Be careful, both engine and muffler are hot.

Return to the track and slowly increase the RPM and duration of the acceleration phase for 10/15min more. Intermittently open the throttle fully and then release it.

After 10/15 minutes of brake-in, your engine is ready for competition.



During the break-in, nuts and bolts tend to loosen. Once the engine is cold, check the torque of the exhaust, head, etc.

## MAINTENANCE



Good maintenance is essential for safe, economical and trouble-free operation. Here you will find a maintenance schedule for your engine. Routine inspection procedures are very simple by using basic tools. Some service tasks that are more difficult or needs special tools must be performed by Vortex technicians or qualified mechanics. Timing schedule periods are only indicative. Extreme carburation set ups highly modify timing schedule periods.

### Maintenance schedule guide an adjustments

Part	Frequency	Operation
Carburetor	Every day	Cleaning
Accelerator cable	Every race	Check
Spark plug	Every race	Check
Exhaust	20 liters	Internal cleaning
piston pin	60 liters	Substitution
Piston pin roller cage	60 liters	Substitution
Connection rod	400 liters	Substitution
Crank shaft pin	200 liters	Substitution
Silver washer	200 liters	Substitution
Crank shaft roller cage	200 liters	Substitution
Oil seals	200/or every crank case opening	Substitution
Crank shaft bearings	800 liters	Substitution

### Torque chart

Part	Torque in Nm
Cylinder head nuts	1.6
Cylinder/crankcase nuts	2.0
Crankcase $\varnothing$ 6 mm screws	1.0/1.1
Clutch discs holder	0.8
Ignition rotor nut	1.8
Exhaust manifold nut	1.0/1.1
Clutch nut	4.5

### General tolerances

Part	Type	Measure	Operation
Cylinder	Ovalization	0.02	Honing
Piston/cylinder	Clearance	0.09	--

Piston types	Sizes $\varnothing$ in mm
W10126/SHF	53.86
W10131/SHF	53.91
W10136/SHF	53.96
W10138/SHF	53.98

## MAINTENANCE DETAIL CHART

In the following section, you will find a detailed most important maintenance jobs to be performed.

### CARBURETOR

#### CLEANING



#### Flat Screwdriver

1. Take the intake silencer off the carburetor by unscrewing the clamp.
2. Disconnect the throttle cable from the carburetor together with the spring and the guillotine slide.
3. Take the carburetor off the engine and open the floating chamber by unscrewing the special cap in the middle of the chamber. Clean the parts, openings and passages with compressed air.
4. Unscrew the main jet by means of a flat screw driver. Replace it with another calibrated differently. Be careful, the washer must be installed in one position only. A wrong assembly may cause the carburetor complete malfunction.
5. Check the plug gasket of the floating chamber is still intact and if damaged, replace it.
6. Close the floating chamber by securing the special cap and mount the carburetor on the engine.
7. Clean the inside of the intake silencer.
8. Mount the intake silencer on the carburetor flange.
9. Tighten it with the specific clamp.

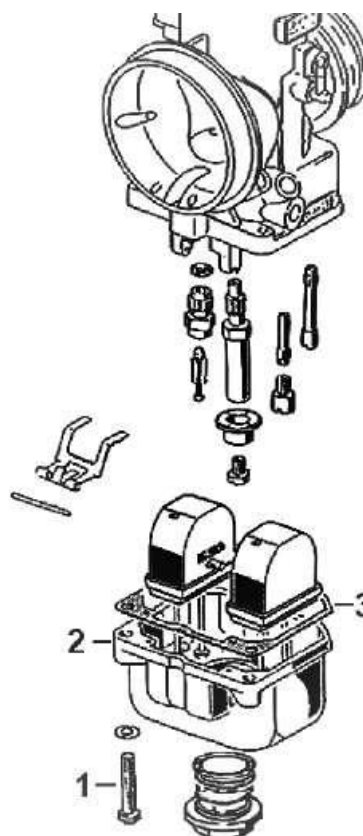

Wrong assembly will cause the loss of the intake silencer.

## CHANGING JETS



**Flat screwdriver**  
**22mm fixed wrench**

Wrong carburation set up could cause sever engine damage.

1. Take the intake silencer off the carburetor by unscrewing the clamp.
2. Disconnect the throttle cable from the carburetor together with the spring and the guillotine slide.
3. Take the carburetor off the engine and open the floating chamber by unscrewing the special cap in the middle of the chamber. Clean the parts, openings and passages with compressed air.
4. Unscrew the main jet by means of a flat plier. Replace it with another calibrated differently. Be careful, the washer must be installed in one position only. A wrong assembly may cause the carburetor complete malfunction.
5. Check the plug gasket of the floating chamber is still intact and if damaged, replace it.
6. Close the floating chamber by securing the special cap and mount the carburetor on the engine.
7. Clean the inside of the intake silencer.
8. Mount the intake silencer on the carburetor flange.
9. Tighten it with the specific clamp.



Wrong assembly will cause the loss of the intake silencer.  
Wrong carburetor assembling may cause engine malfunction and damage.

## SPARK PLUG CLEANING AND REPLACEMENT



**Sparkplug wrench**  
**Metal Brush**



Risk of burning: Perform this task **ONLY** when engine is cool.

Oils produce carbon deposits or residues that make necessary the spark plug to be checked and cleaned, at least every 5 hours.

Remove the spark plug and clean it by using a brass metal brush.

Use a specific spark plug gap gauge to set up correct gap. Correct gap: **0.8 mm**.

Every 30 hours it is highly recommended to change the spark plug.

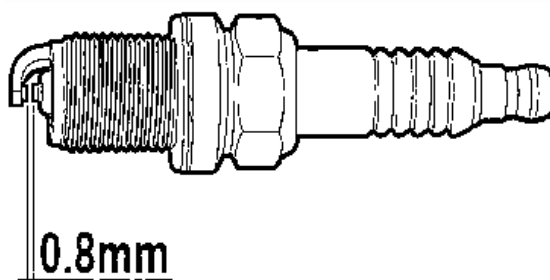

## EXHAUST CLEANING



**Metal Brush**  
**Heater**

Oils produce carbon deposits or residues that make necessary the exhaust to be checked and cleaned, at least every 10 hours.

Disassemble the exhaust from the engine by removing the two springs and check the exhaust carefully.

Heat the exhaust with a heater and remove all carbon deposits with a metal brush.



## CYLINDER HEAD CLEANING



**10mm Tube wrench**  
**Dynamometric wrench**  
**Spark plug**

The oil in the fuel produces carbon deposits and/or residues that makes it necessary to check the cylinder head at least every race.



Be aware, cylinder head combustion chamber volume may vary during the race. Carbon deposits may cause variations in cylinder head volume.

Remove spark plug. Remove the six head nuts and relative washers.

Remove cylinder head by pulling it up carefully.



Use rubber gloves.

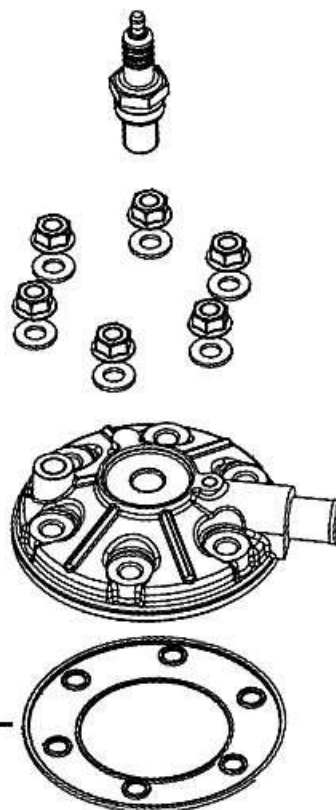

After cleaning the combustion chamber with fuel, reassemble cylinder head. Please check cooper washer, in case it is present, is located in the right position.

This specific washer, assembled wrongly, will change the combustion chamber volume. Insert carefully the head on to the studs and check all O-rings are fitted in the right place. If any is damage, change it. Insert washers and nuts in the studs and tight them manually. Now, by using a dynamometric wrench tighten them alternatively at 16 Nm.

## CYLINDER CHECK AND MAINTENANCE



**10mm Tube wrench  
Dynamometric wrench**



To avoid engine damage, a Vortex qualified mechanic must perform inspection and honing.



Remove exhaust.  
Remove spark plug. Remove the six head nuts and relative washers.

Remove cylinder head by pulling it up carefully.  
Remove the cylinder from the crankcase slowly. Once cylinder is separate from crankcase, hold the connecting rod with the other hand and pull the cylinder out totally by pulling it up carefully.

Every time cylinder is removed we recommend changing cylinder gasket.



Cylinder must be honed when cylinder/piston clearance is more than 0.19mm or when ovalization is more than 0.02 mm.

Change piston (see next page)

New piston cylinder/piston clearance must be 0.09mm.

### REASSEMBLING

Insert a new gasket on to the studs carefully and place it in the crankcase surface flat.

Insert now the cylinder in the studs very carefully. With the other hand close piston ring and inset the piston into the cylinder. If piston ring is not closed totally, risk of cylinder and piston ring is very high Push the cylinder down firmly. Tight four cylinder nuts with dynamometric wrench at 20Nm. Insert cooper washer. Please check cooper washer is located in the right position.

This specific washer, assembled wrongly, will change the combustion chamber volume.

Install, carefully, the head onto the studs and check all o-rings are fitted in the right place. If any is damaged, change it.

Install washers and nuts onto the studs and tight them manually. Now, by using a dynamometric wrench tighten them alternatively at 16 Nm.



Every time cylinder is honed or piston changed, the engine break-in procedure must be performed

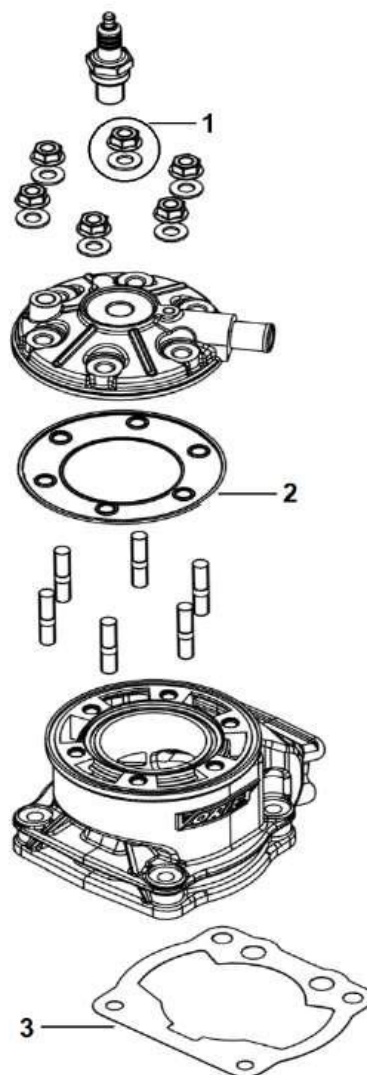

## PISTON CHECK AND MAINTENANCE



**10mm Tube wrench**  
**Dynamometric wrench**



To avoid engine damage, a Vortex qualified mechanic must perform inspection and honing.



Remove exhaust.  
Remove spark plug. Remove the six head nuts and relative washers.

Remove cylinder head by pulling it up carefully.  
Once cylinder is separate from crankcase, hold the connecting rod with the other hand and pull the cylinder out totally by pulling it up carefully.  
Every time cylinder is removed we recommend changing cylinder gasket. Remove the circlips from the piston pin. Push the pin out of the piston.



Before assembling a new piston check dimensional sizes. Correct cylinder/piston clearance is 0.09mm.

## ASSEMBLING

Oil and insert the roller cage in the connecting rod.  
Install the new piston in the connecting rod by placing the arrow stamped in the head of the piston facing the exhaust port. Insert now the piston pin and secure it with the circlips.



Attention, wrong circlips assembling may cause serious damage.

Insert the piston ring in the piston carefully. Check both ends of the piston ring when totally closed have a gap of 0.30/0.35 mm.

Now you are ready to assemble cylinder and cylinder head.



Engine needs a brake-in in session when a new piston has been placed.

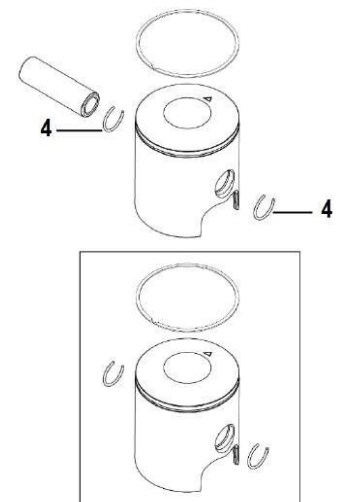
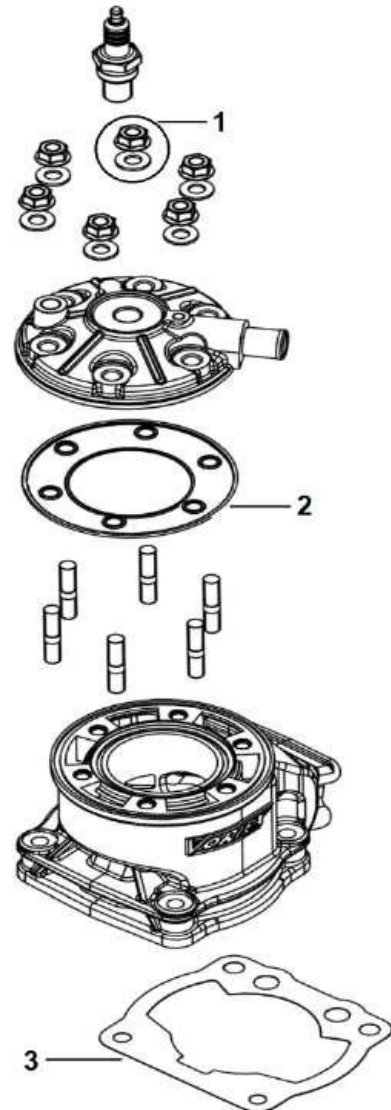

## CHANGING CLUTCH DISCS



4mm fixed wrench  
Dynamometric wrench

Clutch is composed of disc and spacers to transmit the movement to the pinion. Even when the use of clutch is minimum disc suffer wear.

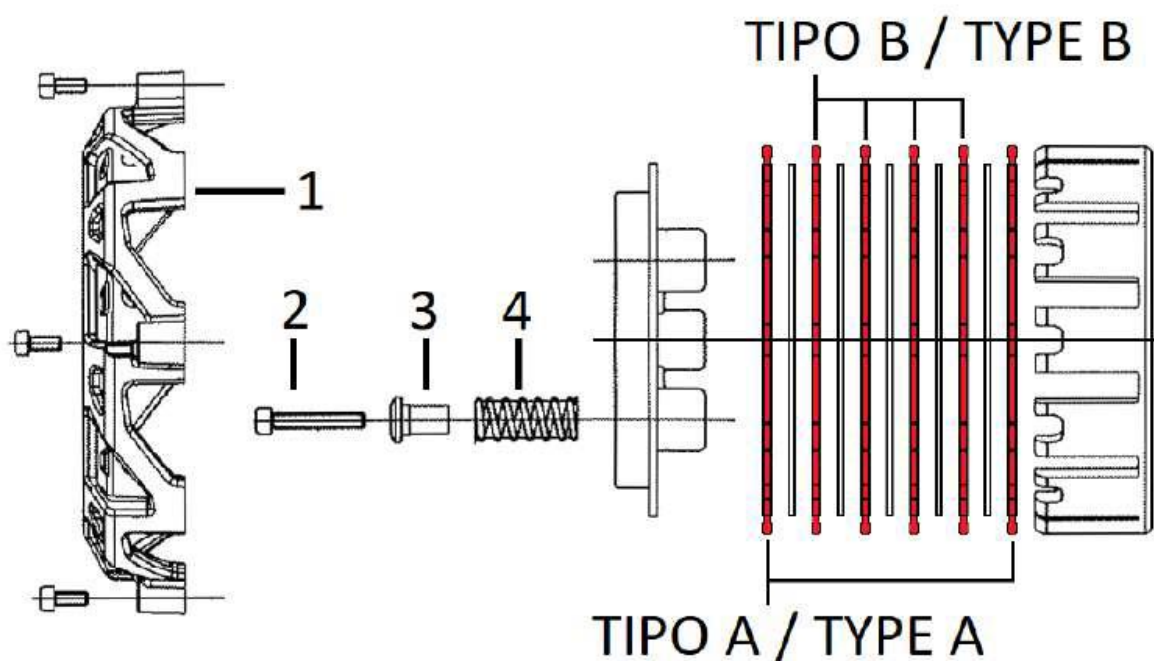

Remove the clutch protection cover. Disassemble the screws that hold the disc and springs. Take screws, springs and spacers off. 2, 3, 4. Now you can disassemble the cover and take the disc and spacer off the clutch bell. Exchange the old disc with new ones.



Be careful, first and last disc (A) of the series are different than the other ones (B). Follow the scheme to assemble discs and spacers. Proceed backwards to reassemble. Screws must be tightened 0.8Nm

